

The Easy-100

No-tune 70cm to 2.4GHz uplink converter for QO-100

Most Members will be aware that the world's first geostationary satellite equipped with an amateur radio transponder, Es'hail-2 (also known as QO-100) has been successfully launched thanks to AMSAT-DL and Qatar, and is now available for general use.

There are two transponders, for narrowband and wideband (DATV) usage. The satellite downlinks are on 10GHz and can be received online via a dedicated software defined radio (SDR) [1] provided by AMSAT-UK and BATC; DIY receivers are also straightforward and require little more than an old Sky satellite dish and a £10 RTL-type SDR dongle running on a smartphone or PC.

Getting signals up to the satellite is trickier – 2.4GHz all-mode radios are rare. Some people use various kinds of SDR, programmed to the necessary frequency; others have made various solutions from their well-equipped junkboxes. There is at least one commercially-available upconverter, though its price reflects its quality.

What I wanted was a simple, repeatable design made from readily-available parts that don't cost a fortune and, perhaps most importantly, don't require any delicate surface mount construction, computer/SDR programming experience, or exotic test gear to set up. And here it is – see **Photo 1**.

Detailed description

Figure 1 is a full block diagram of the Easy-100. It is a conventional upconverter design, made from off-the-shelf modules. I decided to use 70cm as the drive band because ready-made, stable filters are available for 433MHz (and 2.4GHz) that solve most of the filtering issues well-enough and, more importantly, don't need any setting up. Conveniently, both bands are widely used for

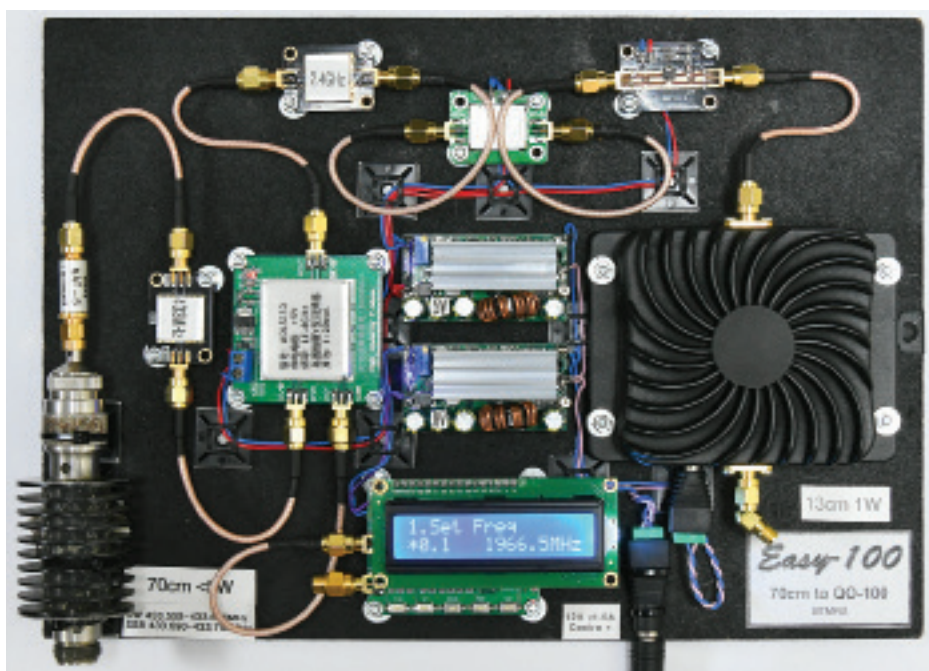

PHOTO 1: General view of a completed Easy-100 upconverter prototype.



PHOTO 2: Early-on in the layout process for a much more compact, cased prototype. Solid SMA adapters are used instead of SMA-SMA leads.

licence-free applications, meaning that there are lots of filters and other parts readily available for those frequencies.

All the gain and power figures in this description are approximate and should be taken

as guidance on how the design works, rather than absolute must-have values.

The 70cm drive signal from the radio, up to about 10W (+40dBm) is reduced to +20dBm (100mW) by the input attenuator(s), discussed in more detail later. Next is a 433MHz bandpass filter to make sure the signal is as clean as possible before reaching the mixer.

A local oscillator (LO) signal is provided by a synthesiser board. The mixer has a built-in local oscillator amplifier, meaning that any LO source of around +4dBm will work fine. The synthesiser board I chose includes a simple user interface of LCD and pushbuttons to set the operating frequency, meaning there's no need for any code writing or PIC programming.

The QO-100 narrowband uplink frequencies are from 2400.050 to 2400.295MHz, corresponding to downlink frequencies of 10489.550 to 10489.795MHz. I decided to make it easy for myself and selected a LO that made the last digits of the drive frequency match those of the downlink, which reduces the necessity for mental arithmetic when tuning. **Table 1** lists some selected dial, uplink and downlink frequencies. **Figure 2** shows the uplink band plan; note that the downlink frequencies are 8089.5MHz higher than the uplink frequencies.

It was convenient to stay near the centre frequency of the 8MHz-wide 433MHz filter,

TABLE 1: Frequency information for 1966.5MHz LO. All figures in MHz.

Radio dial	Uplink	Downlink	Note
433.550	2400.050	10489.550	Start of band
433.555	2400.055	10489.555	CW segment start
433.600	2400.100	10489.600	Narrowband digimodes start
433.620	2400.120	10489.620	Start of digimodes
433.640	2400.140	10489.640	Start of mixed modes
433.690	2400.190	10489.690	SSB segment lower edge
433.740	2400.240	10489.740	Middle of SSB segment
433.795	2400.295	10489.795	Transponder upper limit

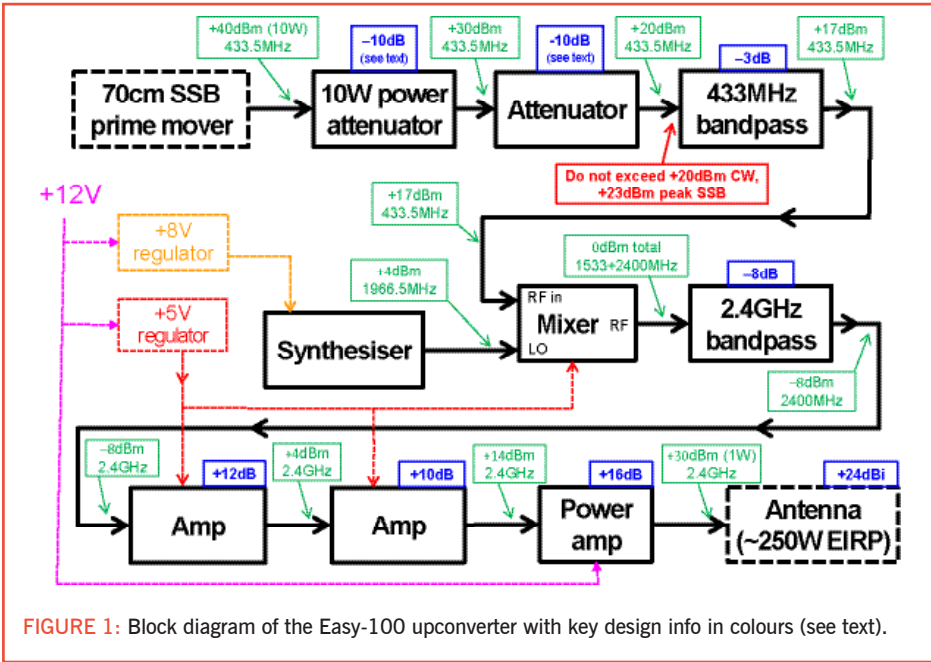

FIGURE 1: Block diagram of the Easy-100 upconverter with key design info in colours (see text).

TABLE 2: Suggested attenuator options.

70cm drive level	Power attenuator	2nd attenuator
1W	10dB	none
2.5W	10dB	4 to 5dB
2.5W	15dB	none
5W	10dB	6 to 8dB
10W	10dB	10dB
10W	20dB	none

(not 78L05) on a small heatsink for 5V would work fine. The only advantage of the switch mode converters I used is that they are higher efficiency than their linear cousins, which may be important if you're operating portable from batteries. One possible disadvantage is that there are no usable mounting holes on the SMPSUs I used – to mount them on the board I used a couple of self-adhesive cable tie bases 'in reverse', cable-tying the bases to the baseboard and then sticking the PSUs on top. **Photo 3** shows what I mean.

The synthesiser I chose is designed to work as a CW or sweep oscillator, though we only need a single frequency here. The instructions in the eBay listing weren't terribly clear (and of course no other documentation was provided) but the important points are that pressing the FUN(ction) button changes the frequency step (0.1, 1, 10, 100, 1000MHz) that the ADD and SUB(tract) buttons increment and decrement the frequency. Use these in combination until the display reads 1966.5MHz and then press and hold FUN until the display says "SAVE". Now use the UP and DOWN buttons until the display reads 6. Scan freqOut. Press FUN to toggle the second line from "ON " to "OFF" – thereby switching off scan mode – then long-press FUN again to SAVE the settings. That's it – the board will remember the settings each time it's powered on. You will note that the synthesiser has two output sockets. Both output the same signal – it doesn't matter which one you use. Although not essential, it's good practice to put a 50Ω SMA terminator (or perhaps simply a 10dB or more attenuator) on the unused port so that it sees a matched load.

As denoted in the block diagram, Figure 1, the Easy-100 needs up to about 10W of SSB drive at 70cm. The input power requirement is very easily changed, eg to suit an FT-817 or similar, simply by changing the input attenuators. I suggest you use a 10dB power (first) attenuator rated for at least 10W, then a lower power attenuator to set the drive level. **Table 2** shows a selection of recommended attenuators for various input powers. Just make sure you don't exceed +20dBm CW or +23dBm PEP SSB at the input to the 433MHz filter.

Overdriving the Easy-100 is a Bad Idea. The middle driver amplifier is running almost flat-out



PHOTO 3: Using cable tie bases 'in reverse' to mount the PSU boards (one with integral heatsink seen here behind the cable tie base).

so I chose 433MHz as the 'base' frequency, meaning that 433.550MHz would equate to an uplink of 2400.050MHz and a downlink on 10489.550MHz. The necessary LO frequency is thus 2400.050-433.550=1966.5MHz.

The active mixer multiplies the 1966.5MHz local oscillator with the 433MHz drive and produces the 2400MHz signal we want – and also an unwanted image at 1966.5-433.5=1533MHz. This is easily removed by a 2.4GHz filter. Although the mixer has a fairly hefty drive signal (about +17dBm, or 50mW), the conversion process is lossy – as is the filter – and we're left with about -8dBm (160µW) of clean 2.4GHz signal.

The final section is a power amplifier strip. Two small wideband amplifier modules increase the level to about +14dBm. This is then fed to an 8W (nominal) Wi-Fi power amplifier. Fortunately we don't need anything like that (saturated) power so the amplifier is used in a more linear part of its range to give a maximum of about 1 watt output. When used with the suggested +24dB antenna (seen on the cover with an earlier prototype

of the Easy-100), that 1W gives an EIRP in the region of 250W – more than adequate to access this very sensitive satellite.

Filters need to see a matched load (usually 50Ω), so in earlier prototypes I used 3dB attenuators in strategic places to reduce [2] any mismatch between stages. Practical tests showed that the various components were well-enough matched to 50Ω that the attenuators were not required, which eased the power gain requirements somewhat.

Construction notes

Construction is remarkably straightforward for a UHF and microwave design thanks to the use of modules and SMA interconnects. Provided you observe the inputs and outputs of the boards, all should go well. The layout seen in the photos is by no means the only possibility: I arranged it that way to make it easy to see what is going on. Another prototype, in an early stage of construction, is seen in **Photo 2**.

Although the suggested power amplifier operates from nominally 12V (it has an internal voltage regulator), other modules require different supplies. The synthesiser needs around 8V, while the mixer and low power amplifiers all need +5V. In early prototypes I used some cheap and cheerful linear regulators for 5V and a tiny switch mode PSU for the 8V supply. The current demands of the low power amplifiers caused the small linear regulators to run very hot. Furthermore, the SMPSU board lacked an input reservoir capacitor and put several volts of noise onto the 12V line. So I decided on an overkill approach and replaced them with two well-behaved, buck-boost converters rated at 3A output. They were £2.30 each, hardly a financial burden. You can, of course, use any regulators you like – eg a 7808 for the 8V rail and a 7805

Giles Read, G1MFG
giles@rsgb.org.uk

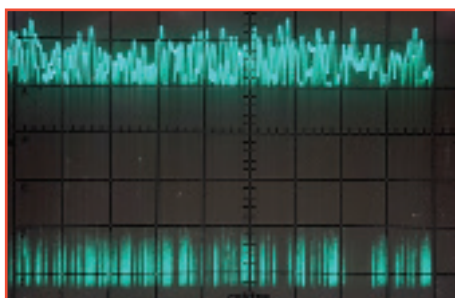

PHOTO 4: Output characteristic with unmodified power amplifier VOX (see text).

(but is still surprisingly linear). Increasing the drive power will simply saturate it and won't get you significantly more than the specified 1W output at 2.4GHz. You may be able to get more power if you use a different driver amplifier, of course, but you really *don't* need more than a watt or so into a decent antenna to get a good signal into the satellite.

One way of setting up the Easy-100 with your radio is to monitor the current drawn by the whole thing. My prototypes generally required somewhere in the region of 220mA with the PA unpowered, 600mA with the PA connected, and 1.2 to 1.5A on transmit. The simple rule is that if you increase the input power from zero there will come a point where the current drawn reaches a maximum. That's the maximum power point; back off the drive a little from there.

I was surprised to discover that some of the high power attenuators on eBay and elsewhere are very particular about which end you use as the input. Connecting them the 'wrong' way round will cause them to fail at much less than the specified power. I found this out the hard way. Please read the listings carefully! (Most of the 'directional' attenuators I've seen have the male N plug as the input. That's fine if you intend to attach it to the aerial socket on your radio, but no good if you want a socket as the input to your Easy-100, as seen in the photos).

As supplied, the Wi-Fi power amplifier has a fast transmit-receive switch, which is required in its intended use as a bi-directional pre/power amplifier. Although it works OK as a linear amplifier, the switching at low level introduces distortion into SSB signals, very like a Class B amplifier with a 'dead zone' between speech peaks. **Photo 4** shows a plot of output power vs time as hissed at the microphone; the 'dead zone' is the blank bit in the middle. Fortunately, the VOX

is a simple circuit, easily defeated, and easy to see if you've got it right: the LED is red in receive mode and green in transmit (you'll see it flicker on SSB peaks if you use it unmodified). Open the amplifier case (thereby voiding any warranty you might have had) and solder a 100k to 470k resistor between TP2 and TP4, as shown in **Photo 5**. Be aware that the little orange capacitor beside TP4 is connected to the supply rail, so take care not to short between it and TP4 when you solder the resistor. When you reconnect power you should see the LED remains green all the time. This modification does cause the amplifier to keep the output devices biased, making it run slightly warm, but it shouldn't get more than about 10°C above ambient temperature.

The suggested antenna (see cover) is specified as 24dBi, which gives enough gain for 1W to access QO-100 on SSB. Less power is needed for CW. The synthesiser specified is fine on SSB and CW but probably isn't stable enough for narrowband data or JT modes. Frequency accuracy isn't perfect either. You will more than likely find a discrepancy of to 1 or 2kHz between where you think you 'should' be, and where your signal actually turns up. This is caused by the simple (read 'cheap') crystal reference oscillator on the synthesiser board. The offset will be constant across the band, so once you know you're, say, 1250Hz off it's easy enough to tune a little high or low to compensate. Better synthesisers offer closer frequency tolerance and can often be locked to very accurate references.

Parts sources

Almost all of the parts in the Easy-100 were obtained via eBay and are likely to be readily available for some time. The modules were selected with ease of use as the primary concern: all are ready-built, have SMA connectors so they're easy to interconnect, and require no setting up. If you buy *everything*, the overall parts cost should be somewhere in the region of £150 to £170.

You can save a lot of money by using suitable junkbox parts or other substitutions. For example, my first prototype used an ex-ATV 13cm linear amplifier that I had handy. Any 13cm linear amp capable of 1 to 2W or so will be fine [7].

There are much cheaper synthesisers available, but they usually require programming (often via a short PIC program you'll need to write). I chose the synth specified because it has a built-in user interface and non-volatile memory.

TABLE 3: Specimen elevation and azimuth figures.

Town/city	Elevation	Azimuth
Belfast	20°	143°
Bettyhill	18.6°	147°
Carlisle	22°	147°
Dover	27°	149°
Truro	25.4°	143°

In my first prototypes I used an ex-ATV 13cm linear amplifier, which worked fine; anything linear that will produce a couple of watts is OK.

An abbreviated parts list, omitting things like screws and washers, is as follows.

- 10dB 10W attenuator (about £15)
- 3, 5, 8 or 10dB 0.5W attenuator (see Table 2) (about £4)
- 433MHz bandpass filter (about £5) – search for “BPF 433M”
- 2400MHz bandpass filter (about £5) – search for “BPF 2.45G” or “2450MHz Bandpass Filter”. Note that both types of bandpass filter are often offered in the same listing, along with other frequencies such as 1575, 1090 and 900MHz. Make sure you get the right ones, and note that they all look the same so *label them!*
- Short (10-15cm) SMA to SMA interconnecting leads (about £1 each) – 7 needed.
- 5V and 8V voltage regulators – see text – (about £2.50 each)
- Synthesiser (£33) – search for “140MHz-4.4GHz Frequency Generator”
- ADL5350 mixer module (about £16)
- First low power amplifier – I used “LNA Board Broadband Signal Receiver Low Noise 0.1-6000MHz” (about £3.50)
- Second low power amplifier – I used “0.05-4G NF=0.6dB Wideband Amplifier Signal Module AR1” (about £5); it's based on a SPF5189Z but the listing doesn't mention that. There are many types of low power wideband amplifiers 'out there'. Use Photo 1 for guidance on the types I used. Take the gain specs with a pinch of salt: by 2.4GHz it is significantly less than the low frequency figure quoted.
- Power amplifier (about £35) – search for “2.4GHz 8W amplifier”. Other types may work but the one shown, with its distinctive heatsink, is easy to modify to disable the VOX. This amplifier has a normal-polarity SMA input but a reverse polarity (RP) output socket (see **Photo 6**) but, handily, it comes with a reverse to normal polarity SMA patch lead. The alternative is to buy a RP-to-normal SMA adapter, RP-SMA to N or whatever you find convenient.

You will also need a N socket to SMA socket adapter to go on the end of the 10W attenuator (perhaps £3), SMA socket to N plug adapter to suit the antenna, and odd sundry items like fixings, hook-up wire and a baseboard or chassis.

In a classic case of “do what I say, not what I do”, I deliberately used hardboard for the prototype shown here, just to prove that the basic design is stable even without solid grounding.

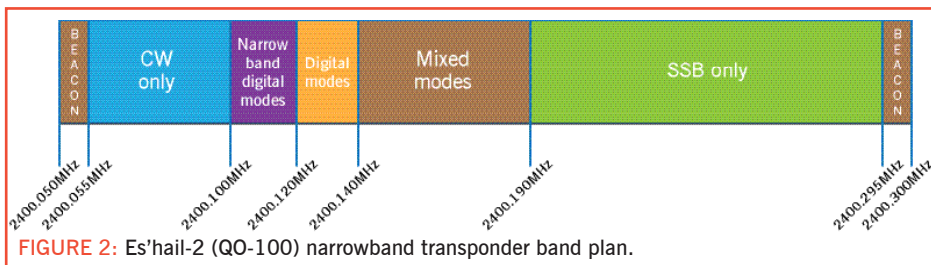

FIGURE 2: Es'hail-2 (QO-100) narrowband transponder band plan.



PHOTO 5: Adding a 100k resistor inside the power amplifier from TP2 to TP4 to defeat the VOX. Most other comparable types of Wi-Fi ‘booster’ can be modified in a similar fashion.

The antenna, a 24dBi semi-parabolic that includes a feed for 2.4GHz, was obtained from a UK supplier [8], part number ANT-24GRID24. It cost around £25 including delivery. [After this article was published the price increased dramatically but there are other suppliers – Ed]

Aiming the dish

It is important that you aim your antenna at the satellite, but you *don't* need to point with any great precision. I recommend you visit Dishpointer [4] to find which direction to face. On the site, enter your town or postcode and select the satellite “25.9E ES” from the drop-down list and then click Search. You’ll get a map telling you the direction and elevation. From Bedford, the azimuth is about 148 degrees and elevation about 25.5 degrees, though it’s not terribly critical. Once you see your signals on the waterfall [1] you can adjust the position for strongest signal.

Table 3 gives some specimen aiming figures for different parts of the UK using information from [4]. The range, south to north, is roughly 18 to 27° elevation; azimuth, west to east, ranges from 143 to 149° (ie all southeast-ish).

The receive antenna on Es’hail-2 is circularly polarised, but the antenna I’m suggesting here is linearly polarised. It will work perfectly well; using a linear-to-circular link simply means there’s an extra 3dB loss (so you need twice as much signal). The Easy-100 has more than enough power to overcome this.

Using the Easy-100

You will need some sort of receiver in order to hear/see your signals. There are many published solutions, including a discussion in last month’s GHz Bands. It’s also worth looking at [5]. But the easiest solution, to start with, is the BATC/AMSAT websdr [1].

DO NOT USE FM. Please, please follow the band plan, as shown in Figure 2. Note that the frequencies shown there are *uplink* frequencies. Some sample input (dial), uplink and output frequencies are shown in Table 1.



PHOTO 6: Reverse polarity SMA socket (on PA).

To make a call,

- Select a clear frequency on the downlink
- Set your transmitter to the appropriate mode (eg CW or upper sideband, USB)
- Monitor the downlink frequency as you transmit to check that your signal is clean, remembering you may have to tune slightly off the ‘should be’ frequency
- Call CQ and enjoy working people 5/9 over a third of the world!

It is very important that you don’t transmit too much power to the satellite. It will sound a siren on your downlink frequency if you are too ‘loud’, one reason it’s important to monitor your downlink audio. If someone advises you to turn your power down, please do so. The easiest way is simply to reduce the mic gain.

Keep your transmit power as low as possible; once you’ve established how much (or little) power you need to access the satellite there is no reason to increase it. People have reported successful (digital) contacts through the satellite with as little as 50mW to a 95cm dish, so 1W to a comparably sized Wi-Fi antenna is potentially quite a big signal.

There will be about a quarter of a second delay between your transmission and hearing the signal coming back down to earth. This is because although the signal is travelling at the speed of light (and there’s no significant delay in the satellite itself), the total path is over 70,000km and that’s far enough to be noticeable by ear. The BATC/AMSAT websdr at Goonhilly is amazingly fast and doesn’t add significantly to the delay; it’s easily fast enough to conduct a QSO.

Performance

I make no claims of earth-shattering performance. The main limiting factor is the local oscillator synthesiser, which is neither particularly clean nor stable. It’s perfectly good enough for SSB and CW, but I can’t guarantee it will work well with narrowband datamodes that require very good frequency stability. However, as this is a modular, plug-together design it’s easy enough to substitute a different, more stable LO at a later date.

Spurious performance, intermodulation and suchlike are also less than perfect. In particular, the synthesiser has spurs at about $\pm 25\text{MHz}$ roughly 30dB down on the wanted signal; after the mixer the *lower* spur is filtered out but there will still be about -30dBc at 2425MHz. This is still well within the amateur allocation so although undesirable, is not (in my opinion) a disaster. But I strongly recommend the Easy-100 is ONLY used for earth-to-space transmissions rather than terrestrial communications, to avoid possible interference to other band users. There’s not much Wi-Fi in space except inside the ISS, and you’re very unlikely to interfere with that.

Discussions with Dave Crump, G8GKQ suggest that the Easy-100 should be stable enough for digital ATV. You’ll need to generate a DATV signal centered on 434MHz or so, and increase the LO frequency a bit to come out on the wideband transponder. However, the 1W output is unlikely to be enough power; DATV on QO-100 needs 30W or so into a 1m dish.

Conclusion

The Easy-100 is an easy to build satellite upconverter that requires minimal skill or experience to construct and use. Whilst its performance isn’t stunning, it *does* work. Please note that UK Foundation licences do not cover the 2.4GHz uplink frequencies.

[Since this article was originally published, an Easy-100 constructor/user group has been established [9] that contains much information including modifications, parts sources, user experiences, photos of different people’s builds plus various hints & tips. It’s free to join. – Ed]

Websearch

- [1] <https://eshail.batc.org.uk/nb/>
- [2] <https://ww2.minicircuits.com/app/AN70-001.pdf>
- [3] www.analog.com/media/en/technical-documentation/evaluation-documentation/adl5350.pdf
- [4] www.dishpointer.com
- [5] https://wiki.batc.org.uk/Es%27hail-2_Basic_Information
- [6] <https://amsat-dl.org/p4-a-nb-transponder-bandplan-and-operating-guidelines/>
- [7] Beware cheap ‘broadband’ power amplifiers. I bought a nice-looking, new, “400MHz-4GHz 1W” TQP3M9103-based power amp for £10 that worked only at 950MHz – it had a *loss* of ~20dB at 2.4GHz!
- [8] www.rfolutions.co.uk/antennas-c8/ant-24grid24-p172
- [9] <https://groups.io/g/Easy-100>